

DATA SHEET

18 FRAME BLOCK-STYLE PLUNGER PUMP



Stainless Steel Model: 1861

Stainless Steel Flushed Model: 1861K



Model 1861K Shown
(Mounting rails sold separately)

FEATURES

- Triplex plunger design delivers high efficiency and low pulsation.
- Durable dual V-Packings are lubricated and cooled by pumped liquid.
- Pre-set Lo-Pressure Seals provide secondary protection against external leaks and require no packing adjustment.
- Special high-density, polished, concentric plungers provide a true wear surface and extended seal life.
- Specially formulated Seals and V-Packings offer unmatched performance and extended life.
- Wet-end easily serviced without entering crankcase.
- Standard NBR seals with alternative options for temperature and chemical compatibility
 - FPM – .0110
 - EPDM – .0220
 - IPFE – .0770

SPECIFICATIONS

	U.S. Measure	Metric Measure
Flow	10 gpm	38 lpm
Pressure Range	100 to 3000 psi	6.9 to 210 bar
Pump RPM*	1429 rpm	1429 rpm
Inlet Pressure Range	+10 to 60 psi	0.69 to 4 bar
Max. Liquid Temperature	160° F	71° C
Above 130°F call Cat Pumps for inlet conditions and elastomer recommendations.		
Bore	0.787"	20 mm
Stroke	1.181"	30 mm
Crankcase Capacity	42 oz.	1.26 l
Inlet Ports (2)	1" NPT(F)	1" NPT(F)
Flushing Ports (2)**	1/4" NPT(F)	1/4" NPT(F)
Discharge Ports (2)	1/2" NPT(F)	1/2" NPT(F)
Shaft Diameter	1.181"	30 mm
Pulley Mounting	Either Side	Either Side
Weight	67 lbs.	30.4 kg
Dimensions	17.40 x 12.99 x 6.41"	442 x 330 x 163 mm

*Pump minimum is 100 RPM.

**Flushed K Models: Special ported inlet manifold permits an external flush liquid providing cooling for hi-temp liquids and lubrication for low lubricity liquids.

ELECTRIC HORSEPOWER REQUIREMENTS

MODELS	FLOW		PRESSURE						RPM
			psi 1500	psi 1800	psi 2000	psi 2200	psi 2500	psi 3000	
	U.S. gpm	lpm	bar 103	bar 124	bar 138	bar 152	bar 172	bar 207	
1861, 1861K	10.0	38	10.3	12.4	13.7	15.1	17.2	20.5	1429
	9.0	34	9.3	11.1	12.4	13.6	15.4	18.5	1188

DETERMINING THE PUMP R.P.M. $\frac{\text{Rated gpm}}{\text{Rated rpm}} = \frac{\text{"Desired" gpm}}{\text{"Desired" rpm}}$

DETERMINING THE REQUIRED H.P. $\frac{\text{Hp (Electric Brake)}}{1460} = \frac{\text{gpm x psi}}{1460}$

DETERMINING MOTOR PULLEY SIZE $\frac{\text{Motor Pulley O.D.}}{\text{Pump rpm}} = \frac{\text{Pump Pulley O.D.}}{\text{Motor rpm}}$

See complete Drive Packages [Includes: pulleys, belts, hubs, key] Tech Bulletin 003.
Refer to pump **Service Manual** for repair procedure and additional technical information.

PARTS LIST

ITEM	PART NUMBER	MATL	PART NUMBER	MATL	DESCRIPTION	QTY
	1861		1861K			
2	30067	STL	30067	STL	Key (M8x7.5x25)	1
5	92538	S	92538	S	Screw, HHC, Sems (M6x16)	8
8	43496	AL	43496	AL	Cover, Bearing (See Tech Bulletin 118)	2
9	815281	FBR	815281	FBR	Shim, Split 2-Pc,	0/2
	814800	S	814800	S	Shim, Split 2-Pc	0/2
10	11340	NBR	11340	NBR	O-Ring, Bearing Cover - 70D	2
11	43495	NBR	43495	NBR	Seal, Oil, Crankshaft - 70D	2
15	39060	STL	39060	STL	Bearing, Roller	2
20	48600	TNM	48600	TNM	Rod, Connecting Assy [11/00]	3
25	43494	FCM	43494	FCM	Crankshaft, Dual End (M30)	1
31	828710	PE	828710	PE	Protector, Oil Cap w/Foam Gasket	1
32	43211	ABS	43211	ABS	Cap, Oil Filler	1
33	14177	NBR	14177	NBR	O-Ring, Filler Cap - 70D	1
37	92241	—	92241	—	Gauge, Oil, w/Gasket - 80D	1
38	44428	NBR	44428	NBR	Gasket, Flat, Oil Gauge - 80D	1
40	92542	S	92542	S	Screw, HHC, Sems (M6x20)	4
48	25625	STCP	25625	STCP	Plug, Drain (1/4"x19 BSP)	1
49	23170	NBR	23170	NBR	O-Ring, Drain Plug - 70D	1
50	43491	AL	43491	AL	Cover, Rear (See Tech Bulletin 118)	1
51	44834	NBR	44834	NBR	O-Ring, Rear Cover - 70D	1
53	115471	AL	115471	AL	Crankcase w/Guide Pins (See Tech Bulletin 118)	1
54	27488	S	27488	S	Pin, Guide	2
55	701268	SS	701268	SS	Stud, Manifold (M10x180)	4
64	43507	CM	43507	CM	Pin, Crosshead	3
65	48892	SSHB	48892	SSHB	Rod, Plunger [3/02]	3
69	126592	STCP R	126592	STCP R	Washer, Seal, Flat	3
70	43500	NBR	43500	NBR	Seal, Oil, Crankcase - 80D	3
75	43506	S	43506	S	Slinger, Barrier	3
88	45675	S	45675	S	Washer, Keyhole (M12)	3
89	45880	SS	45880	SS	Spacer, Collar	3
90	43300	CC	43300	CC	Plunger (M20x77)	3
95	89651	SS	89651	SS	Stud, Plunger Retainer (M6x70)	3
96	43235	PTFE	43235	PTFE	Back-up-Ring, Plunger Retainer	3
97	17399	NBR	17399	NBR	O-Ring, Plunger Retainer - 80D	3
	14160	FPM	14160	FPM	O-Ring, Plunger Retainer - 80D	3
	◆ 46204	EPDM	◆ 46204	EPDM	O-Ring, Plunger Retainer - 70D	3
	701715	IPFE	701715	IPFE	O-Ring, Plunger Retainer	3
98	44041	SS	44041	SS	Gasket, Plunger Retainer	3
99	44031	SS	44031	SS	Retainer, Plunger (M6)	3
100	43509	POP	43509	POP	Retainer, Seal	3
104	11379	NBR	11379	NBR	O-Ring, Inlet Adapter - 70D	3
	700134	FPM	700134	FPM	O-Ring, Inlet Adapter	3
	◆ 701491	EPDM	◆ 701491	EPDM	O-Ring, Inlet Adapter - 70D	3
	702705	IPFE	702705	IPFE	O-Ring, Inlet Adapter	3
105	701270	SS	701270	SS	Adapter, LPS	3
106	44071	NBR	44071	NBR	Seal, LPS w/SS-Spg	3
	44381	FPM	44381	FPM	Seal, LPS w/SS-Spg	3
	◆ 701974	SFTB	◆ 701974	SFTB	Seal, LPS w/SS-Spg	3
	703179	SFTA	703179	SFTA	Seal, LPS w/SS-Spg	3
110	701299	SS	—	—	Manifold, Inlet, Block-Style	1
	—	—	701309	SS	Manifold, Inlet, Block-Style, Flushed	1
111	701342	SS	701342	SS	Plug, Inlet [1"NPT(M)]	1
112	26969	NBR	26969	NBR	O-Ring, Spacer - 70D	15
	28459	FPM	28459	FPM	O-Ring, Spacer	15
	◆ 701863	EPDM	◆ 701863	EPDM	O-Ring, Spacer	15
	702028	IPFE	702028	IPFE	O-Ring, Spacer - 70D	15
113	28204	PTFE	28204	PTFE	Back-up-Ring, Spacer	12
114	701272	SS	701272	SS	Adapter, Valve, IMDM	6
118	701077	SS	—	—	Plug [1/4"NPT(M)]	3
122	43519	PTFE	43519	PTFE	Back-up-Ring, Spacer	3
123	13984	NBR	13984	NBR	O-Ring, Spacer- 70D	3
	14333	FPM	14333	FPM	O-Ring, Spacer	3
	◆ 701945	EPDM	◆ 701945	EPDM	O-Ring, Spacer	3
	703313	IPFE	703313	IPFE	O-Ring, Spacer	3
124	701271	SS	701271	SS	Cylinder, V-Packing	3
126	44164	SS	44164	SS	Adapter, Female	3
127	44607	STG	44607	STG	V-Packing	6
	44386	FPM	44386	FPM	V-Packing	6
128	44165	SS	44165	SS	Adapter, Male	3
162	43248	PTFE	43248	PTFE	Back-up-Ring, Seat	6
163	43249	NBR	43249	NBR	O-Ring, Seat - 80D	6
	44383	FPM	44383	FPM	O-Ring, Seat - 70D	6
	◆ 46206	EPDM	◆ 46206	EPDM	O-Ring, Seat - 70D	6
	701852	IPFE	701852	IPFE	O-Ring, Seat	6
164	44037	SS	44037	SS	Seat	6
166	48793	SS	48793	SS	Valve	6
167	44039	SS	44039	SS	Spring, Valve	6
168	44564	PVDF	44564	PVDF	Retainer, Spring	6
179	701265	SS	701265	SS	Manifold, Valve Block, Block-Style	1
180	701078	SS	701078	SS	Plug [3/8"NPT(M)]	3
181	89628	S	89628	S	Screw, HSH (M12x65)	4

EXPLODED VIEW

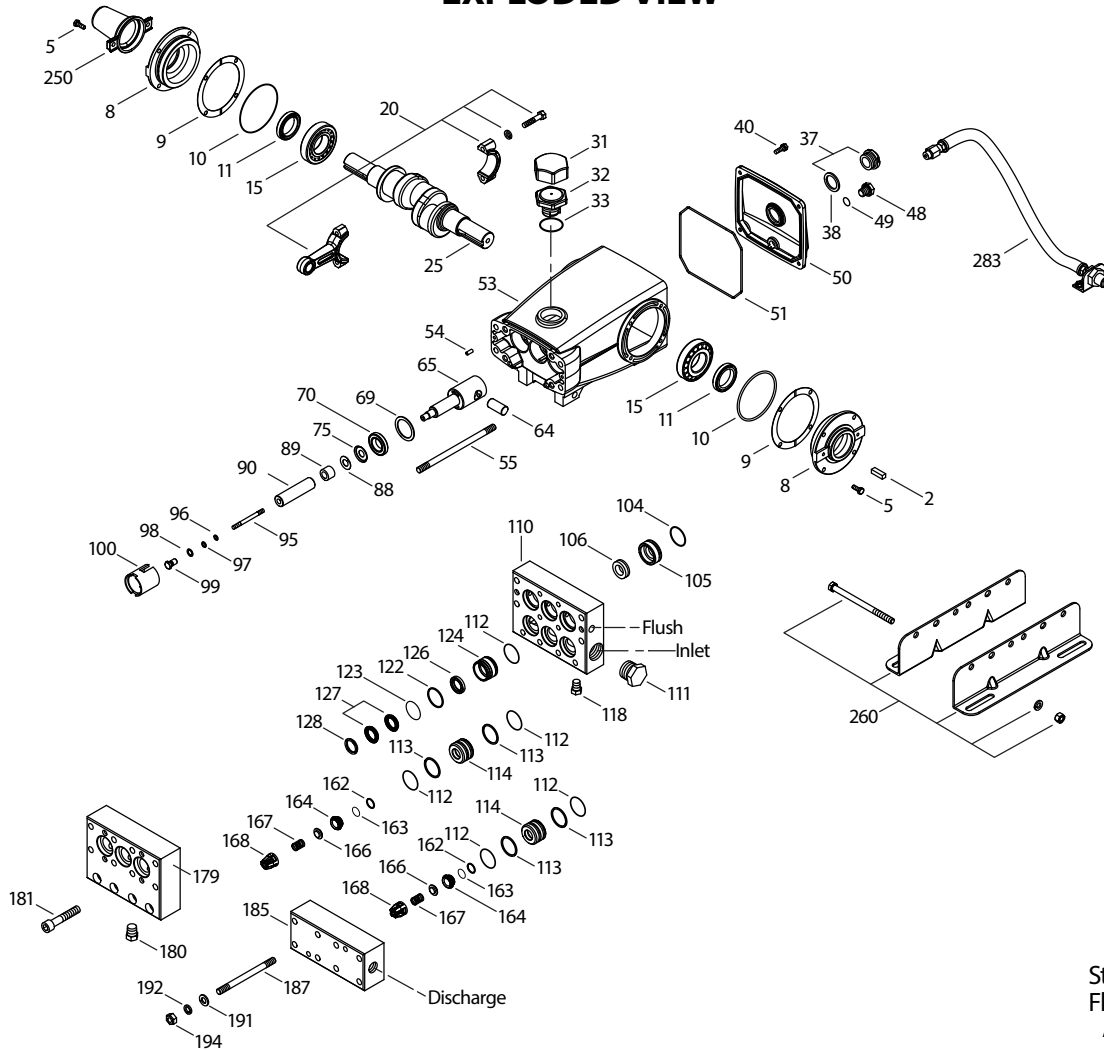

Models
Standard - 1861
Flushed - 1861K
August 2016

ITEM	PART NUMBER	MATL	PART NUMBER	MATL	DESCRIPTION	QTY
185	701300	SS	701300	SS	Manifold, Discharge, Block-Style	1
187	701269	SS	701269	SS	Stud, Manifold (M10x132)	4
191	19934	SS	19934	SS	Washer, Flat (M10)	8
192	15847	S	15847	S	Lockwasher (M10)	8
194	81258	S	81258	S	Nut (M10)	8
250	30764S	NY	30764S	NY	Protector, Shaft w/2 SS Screws	1
255	30264	STZP	30264	STZP	Mount, Direct	1
260	30613	STZPR	30613	STZPR	Mount, Rail, Assy	1
265	30661	—	30661	—	Mounting, Assy (30613, 30206, 30059, 30067, 30764)	1
269	30206	F	30206	F	Pulley, 10.0" AB, [See Tech Bulletin 003]	1
274	30059	STL	30059	STL	Hub, H (M30) [See Tech Bulletin 003]	1
283	34334	—	34334	—	Kit, Oil Drain (3/8"x24")	1
290	6124	—	6124	—	Gasket, Liquid (3 oz.)	1
299	901308	SS	—	—	Head, Complete, Block-Style	1
—	—	—	901309	SS	Head, Complete, Block-Style, Flushed	1
300	701275	NBR*	701275	NBR*	Kit, Seal (Incls: 97,104,106, 112, 113,122,123,127)	1
—	701809	FPM	701809	FPM	Kit, Seal (Incls: 97,104,106, 112,113,122,123,127)	1
—	◆ 701808	EPDM*	◆ 701808	EPDM*	Kit, Seal (Incls: 97,104,106, 112,113,122,123,127)	1
—	76175	IPFE	76175	IPFE	Kit, Seal (Incls: 97,104,106, 112,113,122,123,127)	1
310	701695	NBR	701695	NBR	Kit, Valve (Incls: 112,113,162, 163,164,166,167,168)	2
—	701434	FPM	701434	FPM	Kit, Valve (Incls: 112,113,162, 163,164,166,167,168)	2
—	◆ 701804	EPDM	◆ 701804	EPDM	Kit, Valve (Incls: 112,113,162, 163, 164,166,167,168)	2
—	76695	IPFE	76695	IPFE	Kit, Valve (Incls: 112,113,162, 163, 164,166,167,168)	2
350	30696	STZP	30696	STZP	Plier, Reverse	1
370	—	—	990663	—	Assembly, Flushing, 5 gal, 115V, 1.1Amp, 1/2" NPT	1
—	6107	—	6107	—	Oil Bottles 21 oz. ISO 68 Hydraulic (Fill to specified crankcase capacity prior to start-up)	2
—	6119	—	6119	—	Lubricant, Antiseize (2 oz) (See Tech Bulletin 095)	1

Bold print part numbers are unique to a particular pump model. *Italics are optional items.* ◆ Silicone oil/grease required. R Components comply with RoHS Directive.

[] Date of latest production change. * Review individual parts in each kit for material code identification

View Tech Bulletins 002, 003, 024, 035, 036, 043, 074, 083, 089, 095 and 118 for additional information.

MATERIAL CODES (Not Part of Part Number): ABS=ABS Plastic AL=Aluminum CC=Ceramic CM=Chrome-Moly EPDM=Ethylene Propylene Diene Monomer F=Cast Iron FBR=Fiber FCM=Forged Chrome-Moly FPM=Fluorocarbon IPFE=I-Perfluoroelastomer NBR=Medium Nitrile (Buna-N) NY=Nylon PE=Polyethylene POP=Polypropylene PTFE=Pure Polytetrafluoroethylene PVDF=Polyvinylidene Fluoride S=304SS SFTB=Special Blend PTFE Black SS=316SS SSHB=316SS w/High Strength Brass STCP=Steel/Chrome Plated STG=Special Blend PTFE White STL=Steel STZP=Steel/Zinc Plated TNM=Special High Strength

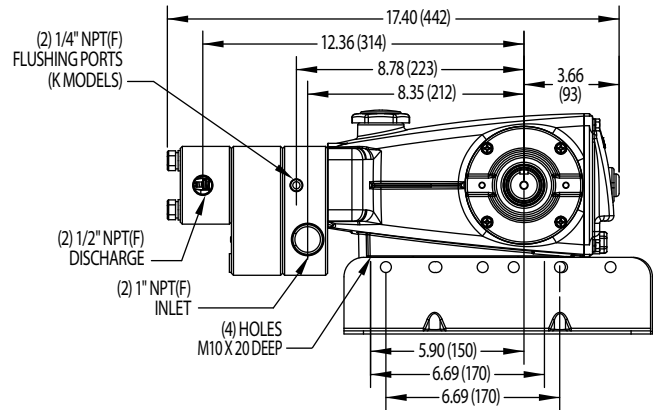
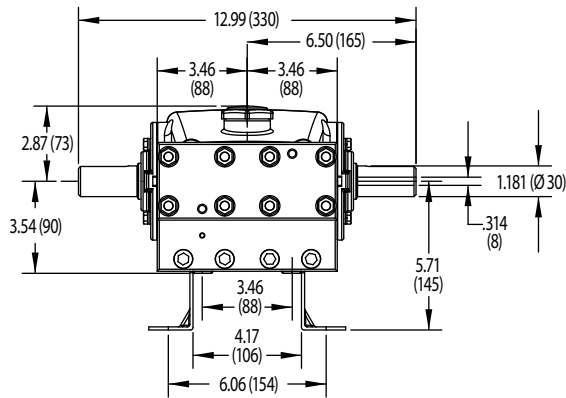

Models 1861 and 1861K

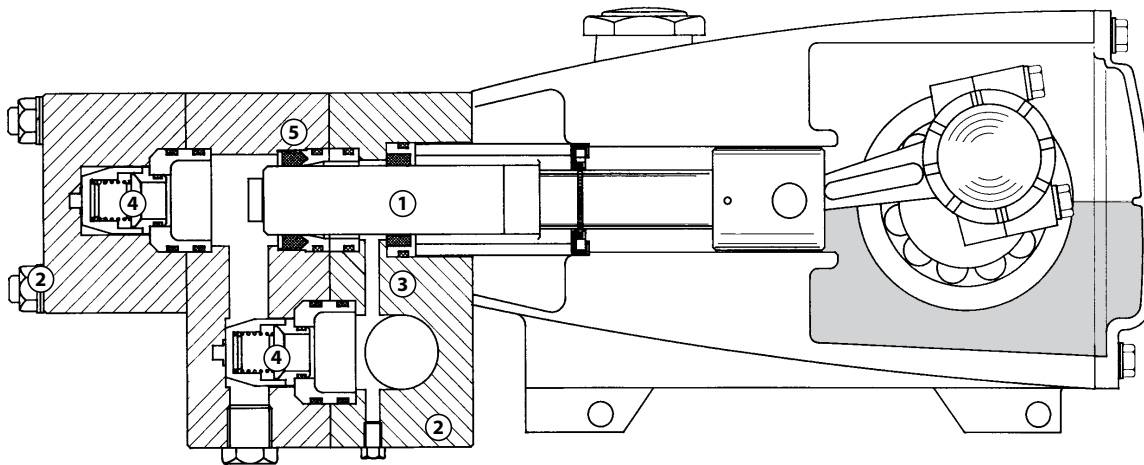

1. Special concentric, high-density, polished, solid ceramic **plungers** provide a true wear surface and extended seal life.
2. **Manifolds** are 316 SS block-style for long term continuous duty and corrosion resistance.

3. **Standard Model:** Lo-Pressure Seals and V-Packings are completely lubricated and cooled by the liquid being pumped.
Flushed Model: Optional special ported Flushed Inlet Manifold permits external flush for lubricating and cooling seals when pumping liquids such as DI water, Hi-Temp or low lubricity.

4. Stainless steel valves, seats and springs provide corrosion-resistance, ultimate seating and extended life.
5. Specially formulated, Cat Pumps exclusive, V-Packings offer unmatched performance and seal life.

⚠ CAUTIONS AND WARNINGS

All High Pressure Systems require a primary pressure regulating device (i.e. regulator, unloader) and a secondary pressure relief device (i.e. pop-off valve, relief valve). Failure to install such relief devices could result in personal injury or damage to pump or property. Cat Pumps does not assume any liability or responsibility for the operation of a customer's high pressure system.

Read all CAUTIONS and WARNINGS before commencing service or operation of any high pressure system. The CAUTIONS and WARNINGS are included in each service manual and with each Accessory Data sheet. CAUTIONS and WARNINGS can also be viewed online at www.catpumps.com/cautions-warnings or can be requested directly from Cat Pumps.

WARRANTY

View the Limited Warranty on-line at www.catpumps.com/warranty.



CAT PUMPS

1681 - 94TH LANE N.E. MINNEAPOLIS, MN 55449-4324
PHONE (763) 780-5440 — FAX (763) 780-2958
e-mail: techsupport@catpumps.com
www.catpumps.com